

| ITEM NO. | PART NUMBER | DESCRIPTION | QTY. |
|----------|-------------|--------------------------|------|
| 1 | 1187 | Assembled pole structure | 1 |
| 2 | 1185 | Footing block | 1 |
| 3 | 1300 | M20 Galv nut | 12 |
| 4 | 1223 | M20 Galv spring washer | 6 |
| 5 | 1222 | M20 Galv flat washer | 12 |
| 6 | 1413 | M20 galv eye-bolt 1.2T | 2 |
| 7 | 1422 | D-shackle 1.5T | 4 |
| 8 | 1423 | M20 galv turn-buckle | 2 |
| 9 | 1420 | 8mm Backstay cable | 2 |

Client:
LOADSCAN

Project
LVS

DO NOT SCALE
Dimensions in mm

3rd Angle
PROJECTION

Drawn by: **Brad Webb**

Drawn Date: **2/02/2017**

Approved by:

TOLERANCE
UNLESS STATED

0-10mm +/- 0.1mm

10-30mm +/- 0.15mm

30-100mm +/- 0.3mm

100mm +/- 0.4mm

Angle +/- 0.25Deg

Material:

Finish:

Colour:

Description:
LVS3-BMF block mount
fixed structure

Drawing Number:
LVS3-BMF

Revision: **B**

Drawing Scale:
1:30

Sheet:
1 of 5

www.LOADSCAN.com

LOAD WOLUME SCANNER

105 Higgins Road, Dinsdale,
Hamilton, New Zealand
Tel: +64 7 847 5777
Fax: +64 7 847 4807

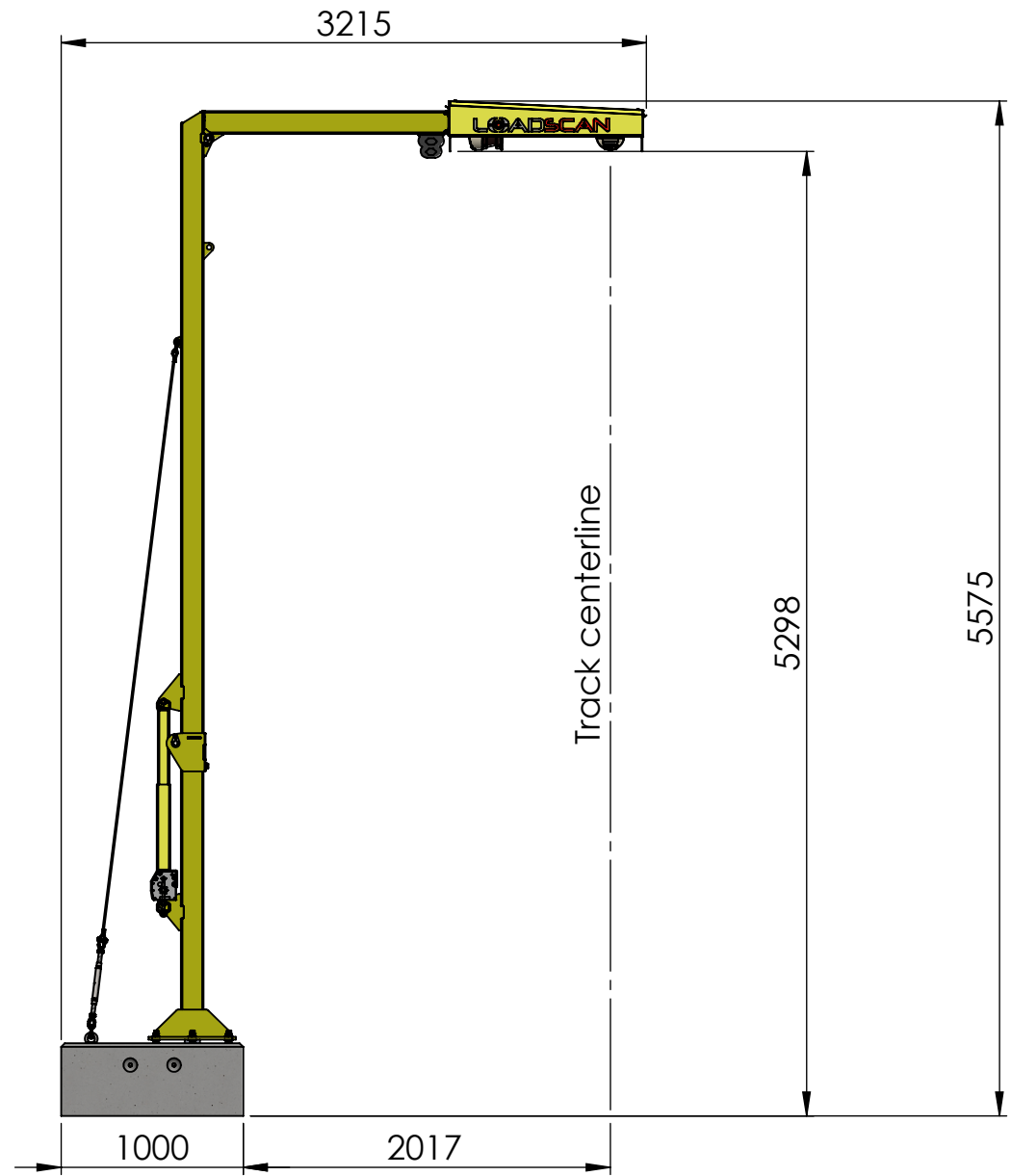
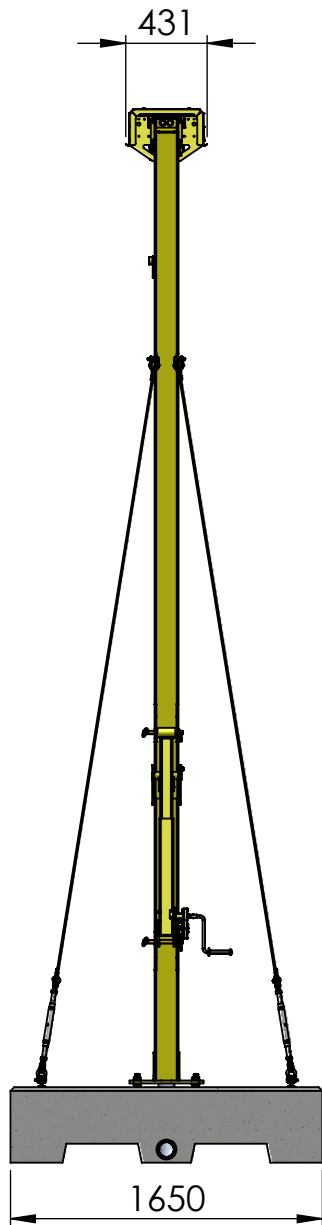

Client:
LOADSCAN

Project
LVS

DO NOT SCALE
Dimensions in mm



Drawn by: **Brad Webb**

Drawn Date: **2/02/2017**

Approved by:

TOLERANCE
UNLESS STATED

0-10mm +/- 0.1mm

10-30mm +/- 0.15mm

30-100mm +/- 0.3mm

100mm +/- 0.4mm

Angle +/- 0.25Deg

Material:

Finish:

Colour:

Description:
LVS3-BMF block mount fixed
structure

Drawing Number:

LVS3-BMF

Revision:

B

Drawing
Scale:

1:40

Sheet:

2 of 5

www.LOADSCAN.com



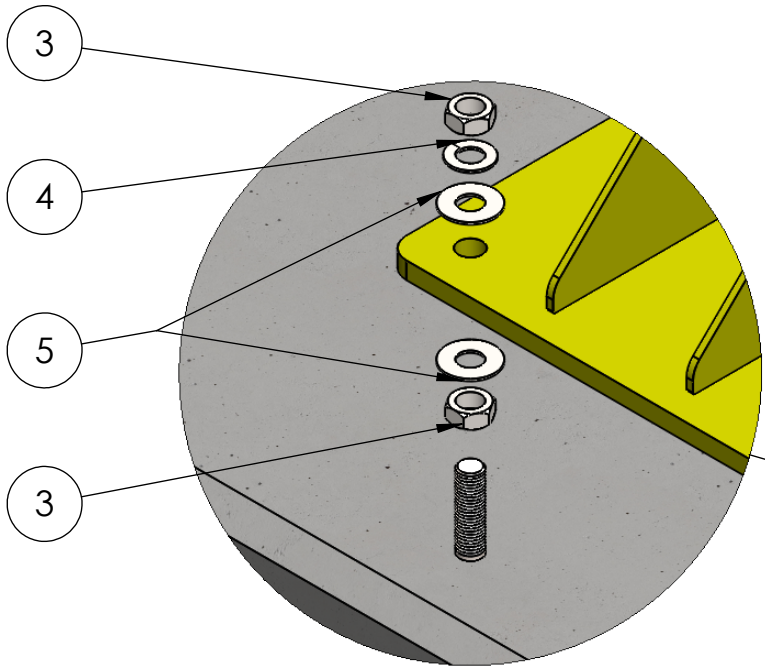

105 Higgins Road, Dinsdale,
Hamilton, New Zealand
Tel: +64 7 847 5777
Fax: +64 7 847 4807

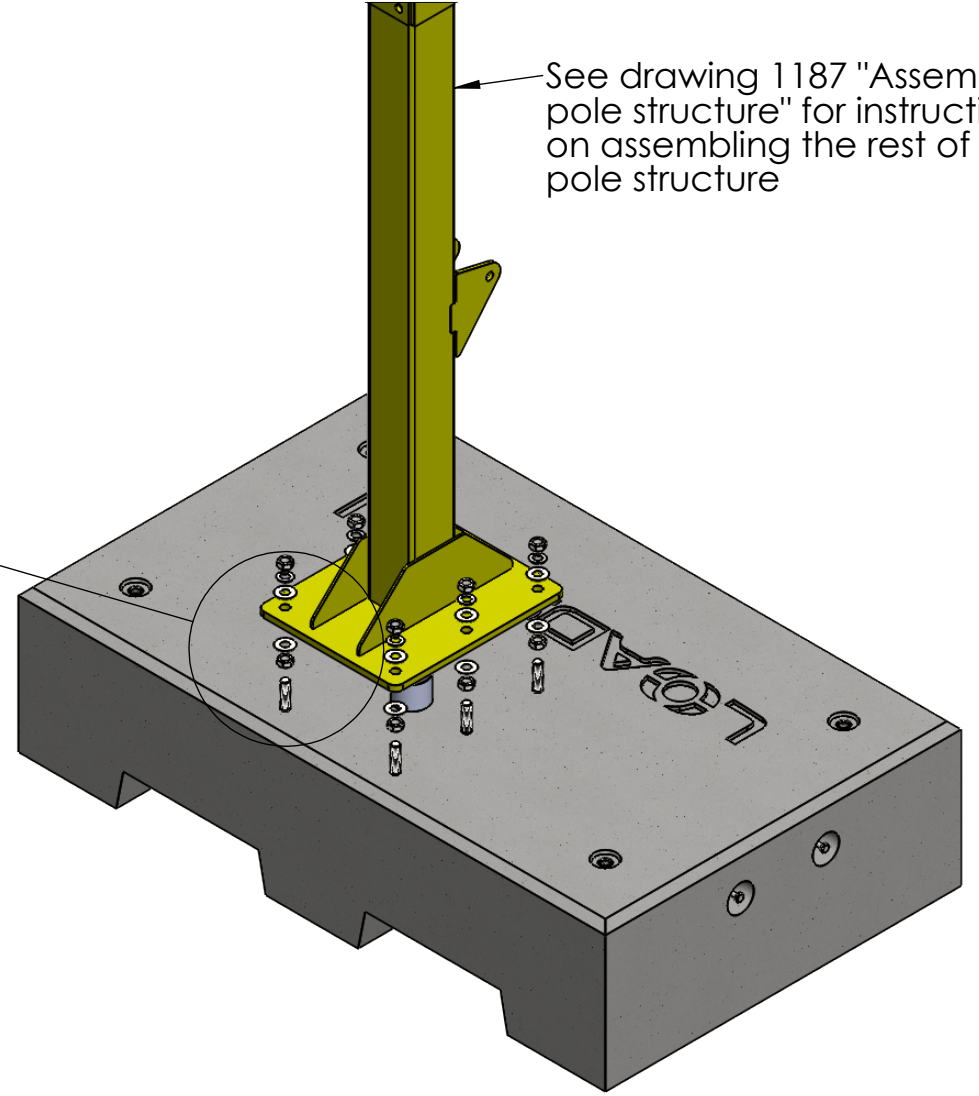

SCALE 1 : 5



See drawing 1187 "Assembled pole structure" for instructions on assembling the rest of the pole structure

| | | | | | | | | |
|----------------------------|--|------------------------------|--|-----------|---|---------------------------|----------------------------------|---|
| Client: LOADSCAN | DO NOT SCALE Dimensions in mm  3rd Angle PROJECTION | Drawn by: Brad Webb | TOLLERANCE UNLESS STATED | Material: | Description: LVS3-BMF block mount fixed structure | Revision: B | Drawing Scale: 1:15 | www.LOADCAN.com  LOAD WOLUME SCANNER 105 Higgins Road, Dinsdale, Hamilton, New Zealand Tel: +64 7 847 5777 Fax: +64 7 847 4807 |
| Project LVS | | Drawn Date: 2/02/2017 | 0-10mm +/- 0.1mm | | | | | |
| | | Approved by: | 10-30mm +/- 0.15mm 30-100mm +/- 0.3mm 100mm +/- 0.4mm Angle +/- 0.25Deg | Colour: | | | | |

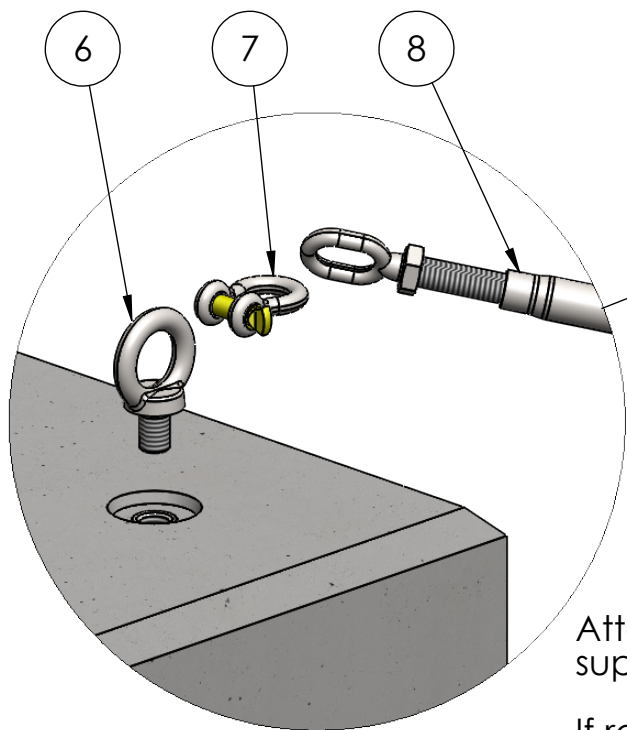

SCALE 1 : 5

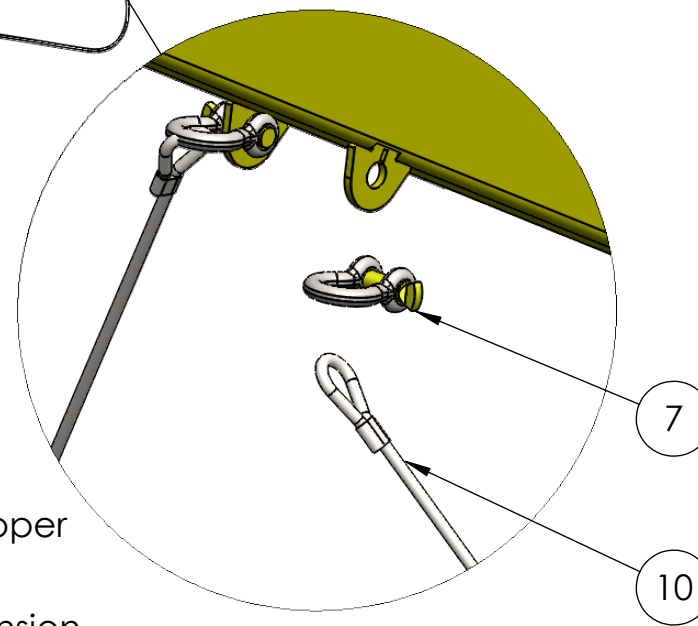
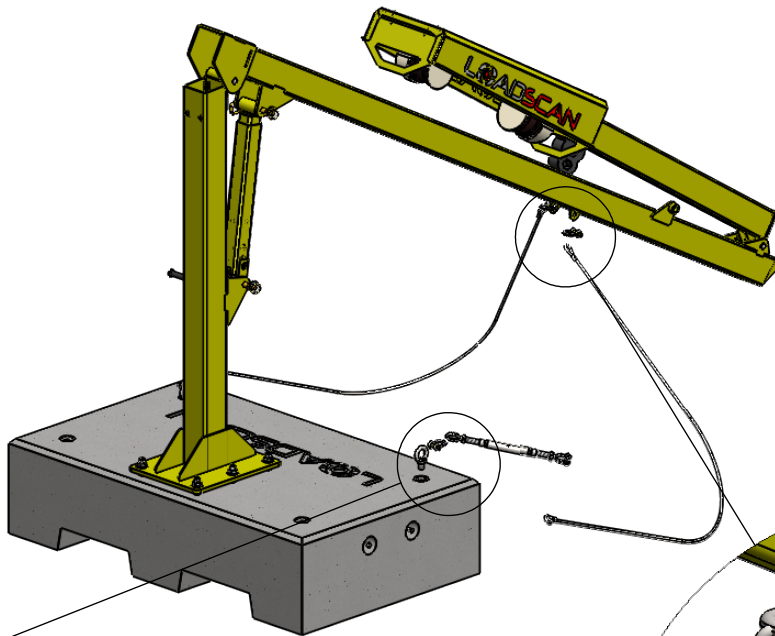

SCALE 1 : 5

Attach backstay cables before rasing the upper support pole.

If rasing the pole for the first time or cable tension has changed, make sure cables do not pull tight before pole is all the way up.

| | | | | | | | | |
|----------------------------|--|------------------------------|--|-----------|---|-----------------------|---|--|
| Client: LOADSCAN | DO NOT SCALE Dimensions in mm  3rd Angle PROJECTION | Drawn by: Brad Webb | TOLLERANCE UNLESS STATED | Material: | Description: LVS3-BMF block mount fixed structure | Revision: B | Drawing Scale: 1:30 Sheet: 4 of 5 | www.LOADSCAN.com LOADSCAN LOAD VOLUME SCANNER 105 Higgins Road, Dinsdale, Hamilton, New Zealand Tel: +64 7 847 5777 Fax: +64 7 847 4807 |
| | | Drawn Date: 2/02/2017 | 0-10mm +/- 0.1mm 10-30mm +/- 0.15mm 30-100mm +/- 0.3mm 100mm +/- 0.4mm Angle +/- 0.25Deg | | | | | |
| Project LVS | | Approved by: | Colour: | | LVS3-BMF | | | |

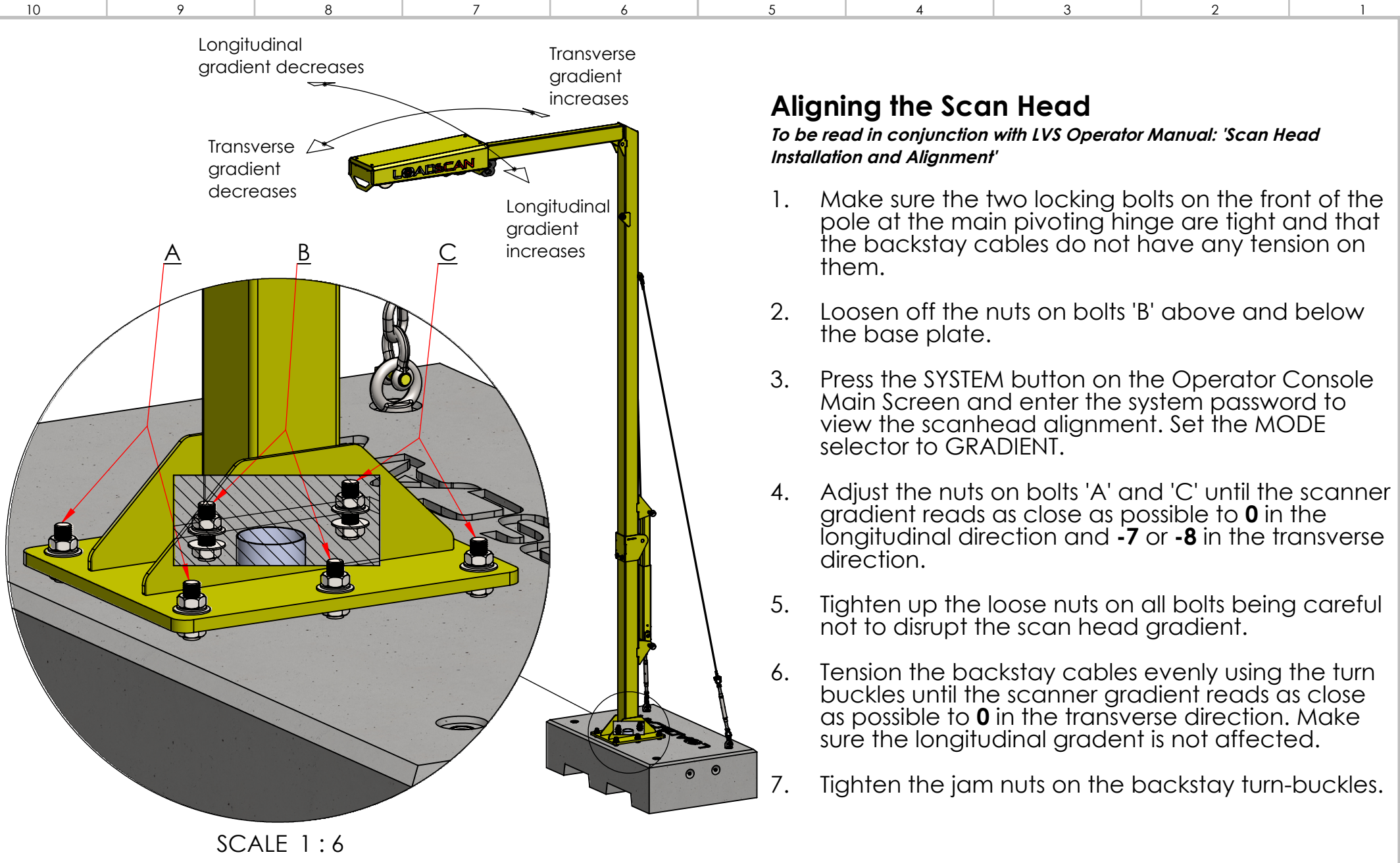



Aligning the Scan Head

To be read in conjunction with LVS Operator Manual: 'Scan Head Installation and Alignment'

1. Make sure the two locking bolts on the front of the pole at the main pivoting hinge are tight and that the backstay cables do not have any tension on them.
2. Loosen off the nuts on bolts 'B' above and below the base plate.
3. Press the SYSTEM button on the Operator Console Main Screen and enter the system password to view the scanhead alignment. Set the MODE selector to GRADIENT.
4. Adjust the nuts on bolts 'A' and 'C' until the scanner gradient reads as close as possible to **0** in the longitudinal direction and **-7** or **-8** in the transverse direction.
5. Tighten up the loose nuts on all bolts being careful not to disrupt the scan head gradient.
6. Tension the backstay cables evenly using the turn buckles until the scanner gradient reads as close as possible to **0** in the transverse direction. Make sure the longitudinal gradient is not affected.
7. Tighten the jam nuts on the backstay turn-buckles.

SCALE 1 : 6

| | | | | | | | | |
|----------------------------|--|------------------------------|--|-----------|--|-------------------------|----------------------------------|---|
| Client: LOADSCAN | DO NOT SCALE Dimensions in mm | Drawn by: Brad Webb | TOLERANCE UNLESS STATED 0-10mm +/- 0.1mm | Material: | Description: LVS3-BMF block mount fixed structure | Revision: B | Drawing Scale: 1:40 | www.LOADSCAN.com  <small>LOAD VOLUME SCANNER</small> 105 Higgins Road, Dinsdale, Hamilton, New Zealand Tel: +64 7 847 5777 Fax: +64 7 847 4807 |
| Project LVS |  3rd Angle PROJECTION | Drawn Date: 2/02/2017 | 10-30mm +/- 0.15mm | Finish: | Drawing Number: LVS3-BMF | Sheet: 5 of 5 | | |
| | | Approved by: | 30-100mm +/- 0.3mm | Colour: | | | | |